

# Finite-State Dimension

Jack J. Dai\*, James I. Lathrop<sup>†</sup>, Jack H. Lutz<sup>‡</sup>, and Elvira Mayordomo<sup>§</sup>

## Abstract

Classical Hausdorff dimension (sometimes called fractal dimension) was recently effectivized using gales (betting strategies that generalize martingales), thereby endowing various complexity classes with dimension structure and also defining the constructive dimensions of individual binary (infinite) sequences. In this paper we use gales computed by multi-account finite-state gamblers to develop the finite-state dimensions of sets of binary sequences and individual binary sequences. The theorem of Eggleston (1949) relating Hausdorff dimension to entropy is shown to hold for finite-state dimension, both in the space of all sequences and in the space of all rational sequences (binary expansions of rational numbers). Every rational sequence has finite-state dimension 0, but every rational number in  $[0, 1]$  is the finite-state dimension of a sequence in the low-level complexity class  $AC_0$ . Our main theorem shows that the finite-state dimension of a sequence is precisely the infimum of all compression ratios achievable on the sequence by information-lossless finite-state compressors.

**KEYWORDS:** bounded-depth circuit, finite-state compressor, finite-state dimension, finite-state gambler, gale, Hausdorff dimension, information-lossless compressor, martingale, normal sequence.

---

\*Department of Mathematics, Iowa State University. Ames, IA 50011, USA. [jdai@iastate.edu](mailto:jdai@iastate.edu) This research was supported in part by National Science Foundation Grants 9610461 and 9988483.

<sup>†</sup>Department of Computer Science, Iowa State University. Ames, IA 50011, USA. [jil@cs.iastate.edu](mailto:jil@cs.iastate.edu)

<sup>‡</sup>Department of Computer Science, Iowa State University. Ames, IA 50011, USA. [lutz@cs.iastate.edu](mailto:lutz@cs.iastate.edu) This research was supported in part by National Science Foundation Grants 9610461 and 9988483.

<sup>§</sup>Departamento de Informática e Ing. de Sistemas, Universidad de Zaragoza. 50015 Zaragoza, SPAIN. [elvira@posta.unizar.es](mailto:elvira@posta.unizar.es) This research was supported in part by Spanish Government MEC projects PB98-0937-C04-02 and TIC98-0973-C03-02. It was done while visiting Iowa State University.

# 1 Introduction

Hausdorff dimension, best known as a powerful tool of fractal geometry, has been known for over fifty years to be closely related to information. For example, Eggleston [5] proved that in the space of all infinite binary sequences, if we let  $\text{FREQ}(\alpha)$  be the set of sequences in which 1 appears with asymptotic frequency  $\alpha$  ( $0 \leq \alpha \leq 1$ ), then the Hausdorff dimension of  $\text{FREQ}(\alpha)$  is precisely  $\mathcal{H}(\alpha)$ , the binary entropy of  $\alpha$ . More recent investigations of Ryabko [16, 17, 18], Staiger [21, 22], and Cai and Hartmanis [3] have explored relationships between Hausdorff dimension and Kolmogorov complexity (algorithmic information).

Hausdorff dimension was originally defined topologically, using open covers by balls of diminishing radii [8, 6]. Very recently, Lutz [14] proved a new characterization of Hausdorff dimension in terms of *gales*, which are betting strategies that generalize martingales. Lutz used this characterization to effectivize Hausdorff dimension, thereby defining dimension in complexity classes [14] and the constructive dimensions of individual sequences [15].

In this paper we extend the effectivization of dimension all the way to the level of finite-state computation. We define a *multi-account finite-state gambler* to be a finite-state gambler that maintains its capital in a portfolio of  $k$  separate accounts, so that capital in one account is shielded from losses in other accounts. (Finite-state gamblers with only one account have been investigated by Schnorr and Stimm [20] and Feder [7].) We use gales induced by multi-account finite-state gamblers to define the *finite-state dimension*  $\text{dim}_{\text{FS}}(X)$  of each set  $X \subseteq \mathbf{C}$ , where  $\mathbf{C}$  is the Cantor space, consisting of all infinite binary sequences. This definition is the natural finite-state effectivization of the gale characterization of classical Hausdorff dimension. In general,  $\text{dim}_{\text{FS}}(X)$  is a real number satisfying

$$0 \leq \text{dim}_{\text{H}}(X) \leq \text{dim}_{\text{FS}}(X) \leq 1,$$

where  $\text{dim}_{\text{H}}(X)$  is the Hausdorff dimension of  $X$ . Like Hausdorff dimension, finite-state dimension has the *stability* property that

$$\text{dim}_{\text{FS}}(X \cup Y) = \max\{\text{dim}_{\text{FS}}(X), \text{dim}_{\text{FS}}(Y)\}$$

for all  $X, Y \subseteq \mathbf{C}$ .

We show that finite-state dimension endows  $\mathbf{Q}$ , the set of all binary expansions of rational numbers in  $[0, 1]$ , with internal dimension structure. We show that the above-mentioned theorem of Eggleston [5] (see also [1]) holds for finite-state dimension in both  $\mathbf{Q}$  and  $\mathbf{C}$ . In particular,  $\mathbf{Q}$  itself has finite-state dimension 1.

For an individual sequence  $S \in \mathbf{C}$ , we define the finite-state dimension of  $S$  to be  $\text{dim}_{\text{FS}}(S) = \text{dim}_{\text{FS}}(\{S\})$ . Each element of  $\mathbf{Q}$  has finite-state dimension 0, while every sequence that is normal in the sense of Borel [2] has finite-state dimension 1. We show that every rational in  $[0, 1]$  is the finite-state dimension of a sequence of very low complexity, namely, a sequence in the logspace-uniform version of the complexity class  $\text{AC}_0$ .

Our main theorem relates finite-state dimension to compressibility by information-lossless finite-state compressors, which were introduced by Huffman [9] and have been extensively investigated. (E.g., see [11] or [12].) Specifically, given such a compressor  $C$  and a sequence  $S \in \mathbf{C}$ , let  $\rho_C(S)$  denote the limit infimum of all compression ratios achieved by  $C$  on prefixes of  $S$ , and let  $\rho_{\text{FS}}(S)$  denote the infimum of all such  $\rho_C(S)$ . Our main theorem says that  $\text{dim}_{\text{FS}}(S)$  is precisely  $\rho_{\text{FS}}(S)$ . Thus, with respect to finite-state computation, dimension and density of information are one and the same for individual sequences.

If  $\rho_{\text{LZ}}(S)$  is the limit infimum of all compression ratios achieved by (any variant of) the Lempel-Ziv compression algorithm [25] on prefixes of a sequence  $S \in \mathbf{C}$ , then it is well known that  $\rho_{\text{LZ}}(S) \leq \rho_{\text{FS}}(S)$  [24]. Thus our main theorem implies that  $\rho_{\text{LZ}}(S) \leq \dim_{\text{FS}}(S)$ . However, this inequality may be proper. For example, Lathrop and Strauss [13] have shown that for every  $\epsilon > 0$  there is a sequence  $S$  that is normal, whence  $\dim_{\text{FS}}(S) = 1$ , but satisfies  $\rho_{\text{LZ}}(S) < \epsilon$ .

We also investigate the role of multiple accounts in our model of finite-state gambling. Multiple accounts are necessary and sufficient for the associated class of gales to be closed under nonnegative, rational, linear combinations. However, we show that the restriction to single-account finite-state gamblers does not alter the finite-state dimension of any set of sequences. In our proof, the single-account gamblers have far more states than their multi-account counterparts, suggesting a possible tradeoff between accounts and states. It is an open question whether this tradeoff is real or merely a feature of our proof.

## 2 Preliminaries

We write  $\mathbb{Z}$  for the set of all integers,  $\mathbb{N}$  for the set of all nonnegative integers,  $\mathbb{Z}^+$  for the set of all positive integers, and  $\mathbb{Q}$  for the set of all rational numbers. We work in the set  $\{0, 1\}^*$  of all (finite, binary) *strings* and in the Cantor space  $\mathbf{C}$  of all (infinite, binary) *sequences*. We write  $|w|$  for the length of a string  $w \in \{0, 1\}^*$ . (We also write  $|X|$  for the cardinality of a finite set  $X$ , relying on context to avoid confusion.) The empty string is denoted  $\lambda$ . For  $S \in \mathbf{C}$  and  $i, j \in \mathbb{N}$ , we write  $S[i..j]$  for the string consisting of the  $i^{\text{th}}$  through  $j^{\text{th}}$  bits of  $S$ , with the understanding that  $S[i..j] = \lambda$  if  $i > j$ . We write  $S[i]$  for  $S[i..i]$  (the  $i^{\text{th}}$  bit of  $S$ ), stipulating that  $S[0]$  is the leftmost bit of  $S$ . For  $w \in \{0, 1\}^*$  and  $S \in \mathbf{C}$ , we write  $w \sqsubseteq S$  if  $w$  is a prefix of  $S$ , i.e., if  $w = S[0..|w| - 1]$ .

A sequence  $C \in \mathbf{C}$  is *normal* [2], and we write  $S \in \text{NORM}$ , if for every  $w \in \{0, 1\}^*$ ,

$$\lim_{n \rightarrow \infty} \frac{1}{n} \left| \left\{ i < n \mid S[i..i + |w| - 1] = w \right\} \right| = 2^{-|w|}.$$

That is,  $S$  is normal if every string  $w$  has asymptotic frequency  $2^{-|w|}$  in  $S$ .

We use the logspace-uniform version of the bounded-depth circuit complexity class  $\text{AC}_0$  [10]. This class consists of all sets  $L \subseteq \{0, 1\}^*$  for which there exist a logspace Turing machine  $M$  and a constant  $d \in \mathbb{Z}^+$  such that the following conditions hold for all  $n \in \mathbb{N}$ .

- (i)  $M(0^n)$  is a standard encoding of a Boolean circuit  $\nu_n : \{0, 1\}^n \rightarrow \{0, 1\}$  consisting of unbounded fan-in AND and OR gates and NOT gates that are applied only to inputs. All gates are allowed unbounded fan-out.
- (ii) The depth of  $\nu_n$  is at most  $d$ .
- (iii) For all  $w \in \{0, 1\}^n$ ,  $w \in L$  iff  $\nu_n(w) = 1$ .

Note that the logspace bound on the Turing machine includes the output and thus implies that there is a polynomial  $q$  such that each  $\nu_n$  has at most  $q(n)$  gates. Using the standard enumeration  $s_0 = \lambda$ ,  $s_1 = 0$ ,  $s_2 = 1$ ,  $s_3 = 00$ ,  $\dots$  of  $\{0, 1\}^*$ , we say that a sequence  $S \in \mathbf{C}$  is in  $\text{AC}_0$  provided that the corresponding set  $L_S = \{s_n \mid S[n] = 1\}$  is in  $\text{AC}_0$ .

### 3 Finite-State Dimension

This section develops finite-state dimension and its fundamental properties. We first review the gale characterization of classical Hausdorff dimension, which motivates our development.

**Definition.** [14] Let  $s \in [0, \infty)$

1. An  $s$ -gale is a function  $d : \{0, 1\}^* \rightarrow [0, \infty)$  that satisfies the condition

$$d(w) = 2^{-s} [d(w0) + d(w1)] \quad (*)$$

for all  $w \in \{0, 1\}^*$ .

2. A *martingale* is a 1-gale.

Intuitively, an  $s$ -gale is a strategy for betting on the successive bits of a sequence  $S \in \mathbf{C}$ . For each prefix  $w$  of  $S$ ,  $d(w)$  is the capital (amount of money) that  $d$  has after betting on the bits  $w$  of  $S$ . When betting on the next bit  $b$  of a prefix  $wb$  of  $S$  (assuming that  $b$  is equally likely to be 0 or 1), condition  $(*)$  tells us that the expected value of  $d(wb)$  – the capital that  $d$  expects to have after this bet – is  $(d(w0) + d(w1))/2 = 2^{s-1}d(w)$ . If  $s = 1$ , this expected value is exactly  $d(w)$  – the capital that  $d$  has before the bet – so the payoffs are “fair.” If  $s < 1$ , this expected value is less than  $d(w)$ , so the payoffs are “less than fair.” Similarly, if  $s > 1$ , the payoffs are “more than fair.”

The following generalization of the Kraft inequality and its corollaries will be useful.

**Lemma 3.1.** [14] Let  $s \in [0, \infty)$ . If  $d$  is an  $s$ -gale and  $B \subseteq \{0, 1\}^*$  is a prefix set, then for all  $w \in \{0, 1\}^*$ ,

$$\sum_{u \in B} 2^{-s|u|} d(wu) \leq d(w).$$

**Corollary 3.2.** [14] Let  $d$  be an  $s$ -gale, where  $s \in [0, \infty)$ . Then for all  $w \in \{0, 1\}^*$ ,  $l \in \mathbb{N}$ , and  $0 < \alpha \in \mathbb{R}$ , there are fewer than  $\frac{2^l}{\alpha}$  strings  $u \in \{0, 1\}^l$  for which  $d(wu) > \alpha 2^{(s-1)l} d(w)$ .

**Corollary 3.3.** [14] If  $d$  is an  $s$ -gale, where  $s \in [0, \infty)$ , then for all  $w, u \in \{0, 1\}^*$ ,

$$d(wu) \leq 2^{s|u|} d(w).$$

Of course the objective of an  $s$ -gale is to win a lot of money.

**Definition.** Let  $d$  be an  $s$ -gale, where  $s \in [0, \infty)$ .

1. We say that  $d$  *succeeds* on a sequence  $S \in \mathbf{C}$  if

$$\limsup_{n \rightarrow \infty} d(S[0..n-1]) = \infty.$$

2. The *success set* of  $d$  is

$$S^\infty[d] = \left\{ S \in \mathbf{C} \mid d \text{ succeeds on } S \right\}.$$

**Observation 3.4.** Let  $s, s' \in [0, \infty)$ . For every  $s$ -gale  $d$ , the function  $d' : \{0, 1\}^* \rightarrow [0, \infty)$  defined by  $d'(w) = 2^{(s'-s)|w|}d(w)$  is an  $s'$ -gale. If  $s \leq s'$ , then  $S^\infty[d] \subseteq S^\infty[d']$ .

**Notation.** For  $X \subseteq \mathbf{C}$ ,  $\mathcal{G}(X)$  is the set of all  $s \in [0, \infty)$  such that there is an  $s$ -gale  $d$  for which  $X \subseteq S^\infty[d]$ .

It was shown in [14] that the following definition is equivalent to the classical definition of Hausdorff dimension in  $\mathbf{C}$ .

**Definition.** The *Hausdorff dimension* of a set  $X \subseteq \mathbf{C}$  is

$$\dim_{\text{H}}(X) = \inf \mathcal{G}(X).$$

In order to define finite-state dimension, we restrict attention to  $s$ -gales that are specified by finite-state devices. These devices place bets, which we require to be rational.

**Definition.** A *binary bet* is a rational number  $r$  such that  $0 \leq r \leq 1$ . We let  $\mathbf{B}$  denote the set of all binary bets, i.e.,  $\mathbf{B} = \mathbb{Q} \cap [0, 1]$ .

Intuitively, if a gambler whose current capital is  $c \in [0, \infty)$  places a binary bet  $r \in \mathbf{B}$  on a (perhaps unknown) bit  $b \in \{0, 1\}$ , then the gambler is betting the fraction  $r$  of its capital that  $b = 1$  and is betting the remainder of its capital that  $b = 0$ . If the payoffs are fair, then after this bet the gambler's capital will be

$$2c[(1-b)(1-r) + br] = \begin{cases} 2rc & \text{if } b = 1 \\ 2(1-r)c & \text{if } b = 0. \end{cases}$$

We now introduce the model of finite-state gambling that is used to develop finite-state dimension. Intuitively, a finite-state gambler is a finite-state device that places  $k$  separate binary bets on each of the successive bits of its input sequence. These bets correspond to  $k$  separate accounts into which the gambler's capital is divided.

**Definition.** If  $k$  is a positive integer, then a  *$k$ -account finite-state gambler ( $k$ -account FSG)* is a 5-tuple

$$G = (Q, \delta, \vec{\beta}, q_0, \vec{c}_0),$$

where

- $Q$  is a nonempty, finite set of *states*,
- $\delta : Q \times \{0, 1\} \rightarrow Q$  is the *transition function*,
- $\vec{\beta} : Q \rightarrow \mathbf{B}^k$  is the *betting function*,
- $q_0 \in Q$  is the *initial state*, and
- $\vec{c}_0 = (c_{0,1}, \dots, c_{0,k})$ , the *initial capital vector*, is a sequence of nonnegative rational numbers.

A *finite state gambler (FSG)* is a  $k$ -account FSG for some positive integer  $k$ .

Note that we require  $k > 0$ . No-account gamblers are not worthy of discussion.

The case  $k = 1$ , where there is only one account, is the model of finite-state gambling that has been considered (in essentially equivalent form) by Schnorr and Stimm [20], Feder [7], and others. In this case we do not regard  $\vec{c}_0$  as a vector, but simply as a nonnegative rational number  $c_0$ , which is the initial capital of  $G$ .

If  $k > 1$ , it is convenient to regard the betting function  $\vec{\beta}: Q \rightarrow \mathbf{B}^k$  as a vector  $\vec{\beta} = (\beta_1, \dots, \beta_k)$  of component betting functions  $\beta_i: Q \rightarrow \mathbf{B}$ , so that

$$\vec{\beta}(q) = (\beta_1(q), \dots, \beta_k(q))$$

for each  $q \in Q$ . If  $k = 1$ , we write  $\beta$  for  $\vec{\beta}$ .

As usual with finite-state transition structures, we extend  $\delta$  to the transition function

$$\delta^*: Q \times \{0, 1\}^* \rightarrow Q$$

defined by the recursion

$$\begin{aligned} \delta^*(q, \lambda) &= q, \\ \delta^*(q, wb) &= \delta(\delta^*(q, w), b) \end{aligned}$$

for all  $q \in Q$ ,  $w \in \{0, 1\}^*$ , and  $b \in \{0, 1\}$ ; we write  $\delta$  for  $\delta^*$ ; and we use the abbreviation  $\delta(w) = \delta(q_0, w)$ .

Intuitively, if a  $k$ -account FSG  $G = (Q, \delta, \vec{\beta}, q_0, \vec{c}_0)$  is in state  $q \in Q$  and its current capital vector is  $\vec{c} = (c_1, \dots, c_k) \in (\mathbb{Q} \cap [0, \infty))^k$ , then for each of its accounts  $i \in \{1, \dots, k\}$ , it places the binary bet  $\beta_i(q) \in \mathbf{B}$ . If the payoffs are fair, then after this bet  $G$  will be in state  $\delta(q, b)$  and its  $i^{\text{th}}$  account will have capital

$$2c_i[(1-b)(1-\beta_i(q)) + b\beta_i(q)] = \begin{cases} 2\beta_i(q)c_i & \text{if } b = 1 \\ 2(1-\beta_i(q))c_i & \text{if } b = 0. \end{cases}$$

This suggests the following definition.

**Definition.** Let  $G = (Q, \delta, \vec{\beta}, q_0, \vec{c}_0)$  be a  $k$ -account finite-state gambler.

1. For each  $1 \leq i \leq k$ , the  $i^{\text{th}}$  *martingale* of  $G$  is the function

$$d_{G,i}: \{0, 1\}^* \rightarrow [0, \infty)$$

defined by the recursion

$$\begin{aligned} d_{G,i}(\lambda) &= c_{0,i}, \\ d_{G,i}(wb) &= 2d_{G,i}(w)[(1-b)(1-\beta_i(\delta(w))) + b\beta_i(\delta(w))] \end{aligned}$$

for all  $w \in \{0, 1\}^*$  and  $b \in \{0, 1\}$ .

2. The *total martingale* (or simply the *martingale*) of  $G$  is the function

$$d_G = \sum_{i=1}^k d_{G,i}.$$

It is clear by inspection that  $d_{G,1}, \dots, d_{G,k}$ , and  $d_G$  are all martingales for every  $k$ -account FSG  $G$ .

**Example 3.5.** The diagram

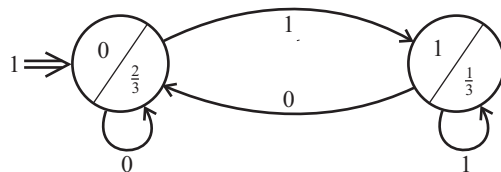

denotes the 1-account FSG  $G = (Q, \delta, \beta, 0, 1)$ , where  $Q = \{0, 1\}$ ,  $\delta(0, 0) = \delta(1, 0) = 0$ ,  $\delta(0, 1) = \delta(1, 1) = 1$ ,  $\beta(0) = \frac{2}{3}$ , and  $\beta(1) = \frac{1}{3}$ . It is easy to verify that  $d_G(\lambda) = 1$ ,  $d_G(1) = \frac{4}{3}$ ,  $d_G(11) = \frac{8}{9}$ , and  $d_G(110) = \frac{32}{27}$ .

**Example 3.6.** The diagram

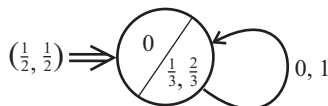

denotes the 2-account FSG  $G = (Q, \delta, \vec{\beta}, 0, (\frac{1}{2}, \frac{1}{2}))$ , where  $Q = \{0\}$ ,  $\delta(0, 0) = \delta(0, 1) = 0$ ,  $\beta_1(0) = \frac{1}{3}$ , and  $\beta_2(0) = \frac{2}{3}$ . Although the two components of  $\vec{\beta}$  make “opposite” bets, these do not “cancel” each other. For example, note that  $d_G(00) = d_G(11) = \frac{10}{9} > 1 = d_G(0) = d_G(1)$ . This is because the separation of accounts causes the effect of a component bet  $\beta_i(q)$  to be proportional to the current capital in the  $i^{\text{th}}$  account.

Many of the  $k$ -account FSGs that we consider have the form  $G = (Q, \delta, \vec{\beta}, q_0, \vec{c})$ , where  $\vec{c} = (\frac{1}{k}, \frac{1}{k}, \dots, \frac{1}{k})$ . In this case we omit  $\vec{c}$  from the notation and diagram, referring simply to the  $k$ -account FSG  $G = (Q, \delta, \vec{\beta}, q_0)$ . Note that such a gambler always has initial capital  $d_G(\lambda) = 1$ .

**Lemma 3.7.** If  $G_1$  is a  $k_1$ -account FSG with  $n_1$  states and  $G_2$  is a  $k_2$ -account FSG with  $n_2$  states, then there is a  $(k_1 + k_2)$ -account FSG  $G$  with  $n_1 n_2$  states such that  $d_G = d_{G_1} + d_{G_2}$ .

**Proof.** We use a product construction. Assume the hypothesis, with

$$G_j = (Q_j, \delta_j, \vec{\beta}_j, q_j, \vec{c}_j)$$

for  $j \in \{1, 2\}$ , where  $\vec{\beta}_j = (\beta_{j,1}, \dots, \beta_{j,k_j})$ ,  $\vec{c}_j = (c_{j,1}, \dots, c_{j,k_j})$ , and we assume without loss of generality that  $Q_1 \cap Q_2 = \emptyset$ . Define the  $(k_1 + k_2)$ -account FSG

$$G = (Q, \delta, \vec{\beta}, q_0, \vec{c}_0),$$

whose components are defined as follows.

(i)  $Q = Q_1 \times Q_2$ .

(ii) For  $q' \in Q_1$ ,  $q'' \in Q_2$ , and  $b \in \{0, 1\}$ ,

$$\delta((q', q''), b) = (\delta_1(q', b), \delta_2(q'', b)).$$

(iii) For  $1 \leq i \leq k_1 + k_2$ ,  $q' \in Q_1$  and  $q'' \in Q_2$ ,

$$\beta_i((q', q'')) = \begin{cases} \beta_{1,i}(q') & \text{if } i \leq k_1 \\ \beta_{2,i-k_1}(q'') & \text{if } i > k_1. \end{cases}$$

(iv)  $q_0 = (q_1, q_2)$ .

(v) For  $1 \leq i \leq k_1 + k_2$ ,

$$c_{0,i} = \begin{cases} c_{1,i} & \text{if } i \leq k_1 \\ c_{2,i-k_1} & \text{if } i > k_1. \end{cases}$$

A routine induction shows that for all  $1 \leq i \leq k_1 + k_2$  and all  $w \in \{0, 1\}^*$ ,

$$d_{G,i}(w) = \begin{cases} d_{G_1,i}(w) & \text{if } i \leq k_1 \\ d_{G_2,i-k_1}(w) & \text{if } i > k_1. \end{cases}$$

It follows that for all  $w \in \{0, 1\}^*$ ,

$$\begin{aligned} d_G(w) &= \sum_{i=1}^{k_1+k_2} d_{G,i}(w) = \sum_{i=1}^{k_1} d_{G_1,i}(w) + \sum_{i=1}^{k_2} d_{G_2,i}(w) \\ &= d_{G_1}(w) + d_{G_2}(w), \end{aligned}$$

whence  $d_G = d_{G_1} + d_{G_2}$ . □

By Observation 3.4, an FSG  $G$  defines not only the martingale  $d_G$ , but also an  $s$ -gale for every  $s$ .

**Definition.** For  $s \in [0, \infty)$ , the  $s$ -gale of an FSG  $G$  is the function

$$d_G^{(s)} : \{0, 1\}^* \rightarrow [0, \infty)$$

defined by

$$d_G^{(s)}(w) = 2^{(s-1)|w|} d_G(w)$$

for all  $w \in \{0, 1\}^*$ .

In particular, note that  $d_G^{(1)} = d_G$ .

**Definition.**

1. For  $s \in [0, \infty)$ , a *finite-state  $s$ -gale* is an  $s$ -gale  $d$  for which there exists an FSG  $G$  such that  $d_G^{(s)} = d$ .
2. A *finite-state martingale* is a finite-state 1-gale.

We now use finite-state gales to define finite-state dimension.

**Notation.** For  $X \subseteq \mathbf{C}$ ,  $\mathcal{G}_{\text{FS}}(X)$  is the set of all  $s \in [0, \infty)$  such that there is a finite-state  $s$ -gale  $d$  for which  $X \subseteq S^\infty[d]$ .

**Observation 3.8.** Let  $X, Y \subseteq \mathbf{C}$  and  $s, s' \in [0, \infty)$ .

1. If  $s' \geq s \in \mathcal{G}_{\text{FS}}(X)$ , then  $s' \in \mathcal{G}_{\text{FS}}(X)$ .
2.  $(1, \infty) \subseteq \mathcal{G}_{\text{FS}}(X) \subseteq (0, \infty)$ .
3.  $\mathcal{G}_{\text{FS}}(X) \subseteq \mathcal{G}(X)$ .
4. If  $X \subseteq Y$ , then  $\mathcal{G}_{\text{FS}}(Y) \subseteq \mathcal{G}_{\text{FS}}(X)$ .

**Proof.** Part 1 follows from Observation 3.4. Parts 3 and 4 are obvious, as is the second inclusion in part 2. For the first inclusion in part 2, let  $s \in (1, \infty)$ . Then the  $s$ -gale  $d(w) = 2^{(s-1)|w|}$  testifies that  $s \in \mathcal{G}_{\text{FS}}(\mathbf{C}) \subseteq \mathcal{G}_{\text{FS}}(X)$ .  $\square$

Recalling that the Hausdorff dimension of a set  $X \subseteq \mathbf{C}$  is  $\dim_{\text{H}}(X) = \inf \mathcal{G}(X)$ , it is natural to define the finite-state dimension as follows.

**Definition.** The *finite-state dimension* of a set  $X \subseteq \mathbf{C}$  is

$$\dim_{\text{FS}}(X) = \inf \mathcal{G}_{\text{FS}}(X).$$

Parts 1 and 2 of Observation 3.8 tell us that  $\mathcal{G}_{\text{FS}}(X)$  is always of the form  $(s^*, \infty)$ , where  $0 \leq s^* \leq 1$ , or of the form  $[s^*, \infty)$ , where  $0 < s^* \leq 1$ . In either case, the number  $s^*$  is the finite-state dimension of  $X$ .

Observation 3.8 has the following immediate consequences.

**Observation 3.9.** Let  $X, Y \subseteq \mathbf{C}$ .

1.  $0 \leq \dim_{\text{H}}(X) \leq \dim_{\text{FS}}(X) \leq 1$ .
2. If  $X \subseteq Y$ , then  $\dim_{\text{FS}}(X) \leq \dim_{\text{FS}}(Y)$ .

An important property of Hausdorff dimension is its *stability*, which is the term used by Falconer [6] for the fact that  $\dim_{\text{H}}(X \cup Y)$  is always the maximum of  $\dim_{\text{H}}(X)$  and  $\dim_{\text{H}}(Y)$ . We now show that finite-state dimension has this property.

**Theorem 3.10.** For all  $X, Y \subseteq \mathbf{C}$ ,

$$\dim_{\text{FS}}(X \cup Y) = \max \{ \dim_{\text{FS}}(X), \dim_{\text{FS}}(Y) \}.$$

Thus for all  $X_1, \dots, X_n \subseteq \mathbf{C}$ ,

$$\dim_{\text{FS}} \left( \bigcup_{i=1}^n X_i \right) = \max_{1 \leq i \leq n} \dim_{\text{FS}}(X_i).$$

**Proof.** Let  $X, Y \in \mathbf{C}$ . By Observation 3.9 it suffices to show that

$$\dim_{\text{FS}}(X \cup Y) \leq \max \{ \dim_{\text{FS}}(X), \dim_{\text{FS}}(Y) \}.$$

For this, let  $s > \max \{ \dim_{\text{FS}}(X), \dim_{\text{FS}}(Y) \}$ ; it suffices to show that  $\dim_{\text{FS}}(X \cup Y) \leq s$ .

By our choice of  $s$ , there exist finite-state gamblers  $G_X$  and  $G_Y$  such that

$$X \subseteq S^\infty \left[ d_{G_X}^{(s)} \right], \quad Y \subseteq S^\infty \left[ d_{G_Y}^{(s)} \right].$$

By Lemma 3.7, there is a finite-state gambler  $G$  such that  $d_G = d_{G_X} + d_{G_Y}$ . It follows immediately that  $d_G^{(s)} = d_{G_X}^{(s)} + d_{G_Y}^{(s)}$ , whence

$$X \cup Y \subseteq S^\infty \left[ d_{G_X}^{(s)} \right] \cup S^\infty \left[ d_{G_Y}^{(s)} \right] = S^\infty \left[ d_G^{(s)} \right].$$

This implies that  $\dim_{\text{FS}}(X \cup Y) \leq s$ . □

We conclude this section with an easy technical lemma.

**Definition.** A 1-account FSG  $G = (Q, \delta, \beta, q_0)$  is *nonvanishing* if  $0 < \beta(q) < 1$  for all  $q \in Q$ .

**Lemma 3.11.** For every 1-account FSG  $G$  and every  $\epsilon > 0$ , there is a nonvanishing 1-account FSG  $G'$  such that for all  $w \in \{0, 1\}^*$ ,  $d_{G'}(w) \geq 2^{-\epsilon|w|}d_G(w)$ .

**Proof.** Let  $G = (Q, \delta, \beta, q_0)$  be a 1-account FSG, and let  $\epsilon > 0$ . For each  $q \in Q$ ,

$$1 - 2^{-\epsilon}(1 - \beta(q)) - 2^{-\epsilon}\beta(q) = 1 - 2^{-\epsilon} > 0,$$

so we can fix a rational  $\beta'(q)$  such that

$$2^{-\epsilon}\beta(q) < \beta'(q) < 1 - 2^{-\epsilon}(1 - \beta(q)).$$

Then  $0 < \beta'(q) < 1$  for each  $q \in Q$ , so the 1-account FSG

$$G' = (Q, \delta, \beta', q_0)$$

is nonvanishing. Also, for all  $q \in Q$ ,

$$\beta'(q) \geq 2^{-\epsilon}\beta(q)$$

and

$$1 - \beta'(q) \geq 2^{-\epsilon}(1 - \beta(q)),$$

so for all  $w \in \{0, 1\}^*$ ,  $d_{G'}(w) \geq 2^{-\epsilon|w|}d_G(w)$ . □

## 4 Accounts versus States

We have allowed our finite state gamblers to have multiple accounts. When discussing the finite-state dimensions of individual sequences, as in sections 6 and 7, the multiplicity of accounts obviously contributes nothing. On the other hand, our proof of Theorem 3.10 makes explicit use of the multi-account feature. In this section we discuss the necessity and desirability of multiple accounts.

If  $G$  is a 1-account FSG and  $s \in [0, \infty)$ , then we call  $d_G^{(s)}$  a *1-account finite state  $s$ -gale*, and we call  $d_G$  a *1-account finite-state martingale*.

We begin our discussion by noting that finite-state gales (with multiple accounts) are closed under nonnegative, rational, linear combinations.

**Observation 4.1.** Let  $s \in [0, \infty)$ . If  $d_1, \dots, d_k$  are finite-state  $s$ -gales and  $a_1, \dots, a_k$  are nonnegative rationals, then  $a_1 d_1 + \dots + a_k d_k$  is a finite-state  $s$ -gale.

**Proof.** The case  $s = 1$  follows easily from Lemma 3.7. The general case then follows by Observation 3.4  $\square$

We next show that 1-account finite-state gales do not enjoy this closure property. Our demonstration uses the following finiteness criterion.

**Observation 4.2.** For every 1-account finite-state martingale  $d$ , the set

$$\left\{ \frac{d(w1)}{d(w)} \mid d(w) > 0 \right\}$$

is finite.

**Proof.** Let  $G = (Q, \delta, \beta, q_0, c)$  be a 1-account FSG. Then the definition of  $d_G$  tells us that for all  $w \in \{0, 1\}^*$ ,

$$d_G(w) > 0 \Rightarrow \beta(\delta(w)) = \frac{d_G(w1)}{2d_G(w)}.$$

Since the domain of  $\beta$  is the finite set  $Q$ , the observation follows immediately.  $\square$

**Observation 4.3.** If  $G$  is the 2-account FSG of Example 3.6, then  $d_G$  is not a 1-account finite-state martingale.

**Proof.** For all  $w \in \{0, 1\}^*$ , we have

$$d_G(w) = \frac{1}{2} \left( \frac{2}{3} \right)^{|w|} \left[ 2^{\#(0,w)} + 2^{\#(1,w)} \right],$$

where  $\#(b, w)$  is the number of times the bit  $b$  appears in the string  $w$ . In particular, for all  $n \in \mathbb{N}$ , we have

$$d_G(0^n) = \frac{1}{2} \left( \frac{2}{3} \right)^n (2^n + 1)$$

and

$$d_G(0^n 1) = \frac{1}{2} \left( \frac{2}{3} \right)^{n+1} (2^n + 2),$$

so

$$\frac{d_G(0^n 1)}{d_G(0^n)} = \frac{2 \cdot 2^n + 2}{3 \cdot 2^n + 1}.$$

Since the set

$$\left\{ \frac{2 \cdot 2^n + 2}{3 \cdot 2^n + 1} \mid n \in \mathbb{N} \right\}$$

is infinite, it follows by Observation 4.2 that  $d_G$  is not a 1-account finite-state martingale.  $\square$

Observation 4.3 tells us that multi-account FSGs cannot always be exactly simulated by 1-account FSGs. In contrast with Observation 4.1, it also gives us the following.

**Observation 4.4.** For all  $s \in [0, \infty)$ , there exist 1-account finite-state  $s$ -gales  $d_1$  and  $d_2$  such that  $d_1 + d_2$  is not a 1-account finite-state  $s$ -gale.

**Proof.** Let  $G$  be the 2-account FSG of Example 3.6. For  $i \in \{1, 2\}$ , let  $d_i = d_{G,i}^{(s)}$ . Then  $d_1$  and  $d_2$  are 1-account finite-state  $s$ -gales, but  $d_1 + d_2 = d_G^{(s)}$  is not a 1-account finite-state  $s$ -gale by Observation 4.3.  $\square$

We have designed our FSG model so that the associated gales are closed under nonnegative, rational, linear combinations because this is such a useful closure property. By Observation 4.4, multiple accounts are required for this closure property to hold.

Notwithstanding the usefulness of the above closure property, the question remains whether multiple accounts are strictly necessary for a theory of finite-state dimension. That is, if we define  $\mathcal{G}_{1\text{-acct-FS}}(X)$  to be the set of all  $s \in [0, \infty)$  such that there is a 1-account finite-state  $s$ -gale  $d$  for which  $X \subseteq S^\infty[d]$ , and we define

$$\dim_{1\text{-acct-FS}}(X) = \inf \mathcal{G}_{1\text{-acct-FS}}(X),$$

is there any set  $X \subseteq \mathbf{C}$  for which

$$\dim_{\text{FS}}(X) < \dim_{1\text{-acct-FS}}(X)?$$

The next result shows that multiple accounts are not strictly necessary if we are willing to accept a large blowup in the number of states.

**Theorem 4.5.** For each  $n$ -state,  $k$ -account FSG  $G$  and each  $\epsilon \in (0, 1)$ , if we let  $m = \left\lceil \frac{\log k}{\epsilon} \right\rceil$  and  $N = n(2^m - 1)$ , then there is an  $N$ -state, 1-account FSG  $G'$  such that for all  $s \in [0, 1]$ ,

$$S^\infty[d_G^{(s)}] \subseteq S^\infty[d_{G'}^{(s+\epsilon)}].$$

**Proof.** Let  $G = (Q, \delta, \vec{\beta}, q_0, \vec{c}_0)$  be an  $n$ -state,  $k$ -account FSG, and let  $\epsilon \in (0, 1)$ . Let  $c = \sum_{j=1}^k c_{0,j}$ . If  $k = 1$  or  $c = 0$  the theorem holds trivially, so assume that  $k \geq 2$  and  $c > 0$ . To simplify notation, let  $d_j = d_{G,j}$  for each  $1 \leq j \leq k$ , and let  $d = d_G$ .

For each  $q \in Q$ , let  $G_q = (Q, \delta, \vec{\beta}, q)$ . That is, let  $G_q$  be the FSG obtained from  $G$  by changing the initial state to  $q$  and the initial capital vector to  $(\frac{1}{k}, \frac{1}{k}, \dots, \frac{1}{k})$ . For each  $q \in Q$  and  $1 \leq j \leq k$ , let  $d_{q,j} = d_{G_q,j}$ , and let  $d_q = d_{G_q}$ . (We consistently use  $q$  as a state and  $j$  as an account index, so no confusion will arise between  $d_q$  and  $d_j$ .) Note that for all  $w, u \in \{0, 1\}^*$  and  $1 \leq j \leq k$ , if  $q = \delta(w)$ , then

$$d_{q,j}(u) = \frac{1}{k} \frac{d_j(wu)}{d_j(w)},$$

where we stipulate that this fraction is 0 if  $d_j(w) = 0$ . This implies that for all  $w, u \in \{0, 1\}^*$ , if  $q = \delta(w)$ , then

$$d_q(u) = \frac{1}{k} \sum_{j=1}^k \frac{d_j(wu)}{d_j(w)} \quad (4.1)$$

with the same stipulation.

Let  $m = \left\lceil \frac{\log k}{\epsilon} \right\rceil$ , and define the 1-account FSG  $G' = (Q', \delta', \beta', q'_0)$  whose components are specified as follows.

(i)  $Q' = Q \times \{0, 1\}^{<m}$ .

(ii) For  $q \in Q$ ,  $u \in \{0, 1\}^{<m}$ , and  $b \in \{0, 1\}$ ,

$$\delta'((q, u), b) = \begin{cases} (q, ub) & \text{if } |u| < m - 1 \\ (\delta(q, ub), \lambda) & \text{if } |u| = m - 1. \end{cases}$$

(iii) For  $q \in Q$  and  $u \in \{0, 1\}^{<m}$ ,

$$\beta'(q, u) = \begin{cases} \frac{d_q(u1)}{2d_q(u)} & \text{if } d_q(u) > 0 \\ \frac{1}{2} & \text{if } d_q(u) = 0. \end{cases}$$

(iv)  $q'_0 = (q_0, \lambda)$ .

Intuitively, the states of  $G'$  are arranged in  $n$  trees, one for each state of  $G$ . The tree for  $q$  simulates the martingale  $d_q$  (which is not necessarily the martingale of any 1-account FSG) for  $m$  steps before passing control to the root of another tree. It is clear that  $G'$  is an  $N$ -state, 1-account FSG, where  $N = n(2^m - 1)$ . Let  $d' = d_{G'}$ .

We now show that if  $|w|$  is a multiple of  $m$ ,  $|u| < m$ , and  $q = \delta(w)$ , then

$$d'(wu) = d'(w)d_q(u). \quad (4.2)$$

We use induction on the string  $u$ . It holds trivially if  $u = \lambda$ . Assume that (4.2) holds for  $u$ , where  $|u| < m - 1$ , and let  $b \in \{0, 1\}$ . Then the definition of  $d'$  and the induction hypothesis tell us that

$$\begin{aligned} d'(wub) &= 2d'(wu) [(1 - b)(1 - \beta'(q, u)) + b\beta'(q, u)] \\ &= 2d'(w)d_q(u) [(1 - b)(1 - \beta'(q, u)) + b\beta'(q, u)]. \end{aligned}$$

If  $d_q(u) = 0$ , this immediately tells us that  $d'(wub) = 0 = d'(w)d_q(ub)$ , whence (4.2) holds for  $ub$ . If  $d_q(u) > 0$ , it tells us that

$$\begin{aligned} d'(wub) &= 2d'(w)d_q(u) \left[ (1 - b) \left( 1 - \frac{d_q(u1)}{2d_q(u)} \right) + b \frac{d_q(u1)}{2d_q(u)} \right] \\ &= d'(w) [(1 - b)(2d_q(u) - d_q(u1)) + bd_q(u1)] \\ &= d'(w)d_q(ub), \end{aligned}$$

whence (4.2) again holds for  $ub$ . This completes the verification of (4.2).

For all  $w \in \{0, 1\}^*$ , if we write  $w = w_0 w_1 \cdots w_l$ , where  $|w_i| = m$  for all  $0 \leq i < l$  and  $|w_l| < m$ , then (4.2) tells us inductively that

$$d'(w) = \prod_{i=0}^l d_{q_i}(w_i), \quad (4.3)$$

where  $q_i = \delta(w_0 \cdots w_{i-1})$  for all  $0 \leq i \leq l$ . If  $w_l = \lambda$  here, then (4.3) and (4.1) tell us that

$$\begin{aligned} d'(w) &= \prod_{i=0}^{l-1} d_{q_i}(w_i) \\ &= \prod_{i=0}^{l-1} \frac{1}{k} \sum_{j=1}^k \frac{d_j(w_0 \cdots w_i)}{d_j(w_0 \cdots w_{i-1})} \\ &\geq k^{-l} \sum_{j=1}^k \prod_{i=0}^{l-1} \frac{d_j(w_0 \cdots w_i)}{d_j(w_0 \cdots w_{i-1})} \\ &= k^{-l} \sum_{j=1}^k \frac{d_j(w)}{c_j} \\ &\geq \frac{1}{ck^l} d(w). \end{aligned}$$

This shows that for all  $w \in \{0, 1\}^*$ , if  $|w| = lm$ , then

$$d'(w) \geq \frac{1}{ck^l} d(w),$$

whence our choice of  $m$  tells us that

$$\begin{aligned} d'^{(1+\epsilon)}(w) &= 2^{\epsilon lm} d'(w) \\ &\geq 2^{\epsilon lm} \frac{1}{ck^l} d(w) \\ &\geq \frac{1}{c} d(w). \end{aligned}$$

We have now shown that for all  $w \in \{0, 1\}^*$ , if  $|w|$  is a multiple of  $m$ , then

$$d'^{(1+\epsilon)}(w) \geq \frac{1}{c} d(w). \quad (4.4)$$

Now let  $s \in [0, 1]$ . To complete the proof it suffices to show that  $S^\infty[d^{(s)}] \subseteq S^\infty[d'^{(s+\epsilon)}]$ . For this, let  $A \in S^\infty[d^{(s)}]$ . To see that  $A \in S^\infty[d'^{(s+\epsilon)}]$ , let  $r$  be an arbitrarily large positive integer. Since  $A \in S^\infty[d^{(s)}]$ , there exists  $x \sqsubseteq A$  such that  $d^{(s)}(x) \geq 2^m cr$ . Let  $w$  be the longest prefix of  $x$  whose

length is a multiple of  $m$ , and let  $i = |x| - |w|$ . Then  $w \sqsubseteq A$ , and (4.4) tells us that

$$\begin{aligned}
d^{(s+\epsilon)}(w) &= 2^{(s-1)|w|} d^{(1+\epsilon)}(w) \\
&\geq \frac{1}{c} 2^{(s-1)|w|} d(w) \\
&\geq \frac{1}{c} 2^{(s-1)|w|-i} d(x) \\
&= \frac{1}{c} 2^{(s-1)|w|-i} 2^{(1-s)|x|} d^{(s)}(x) \\
&= \frac{1}{c} 2^{-is} d^{(s)}(x) \\
&\geq 2^{m-is} r \\
&\geq r.
\end{aligned}$$

Since  $r$  is arbitrary here, this shows that  $A \in S^\infty[d^{(s+\epsilon)}]$ .  $\square$

**Corollary 4.6.** For all  $X \subseteq \mathbf{C}$ ,

$$\dim_{1\text{-acct-FS}}(X) = \dim_{\text{FS}}(X).$$

**Proof.** Let  $X \subseteq \mathbf{C}$  and  $\epsilon \in (0, 1)$ . It is clear that  $\dim_{1\text{-acct-FS}}(X) \geq \dim_{\text{FS}}(X)$ , so it suffices to show that  $\dim_{1\text{-acct-FS}}(X) \leq \dim_{\text{FS}}(X) + 2\epsilon$ .

Let  $s = \dim_{\text{FS}}(X) + \epsilon$ . Then there is an FSG  $G$  such that  $X \subseteq S^\infty[d_G^{(s)}]$ . By Theorem 4.5, then, there is a 1-account FSG  $G'$  such that  $X \subseteq S^\infty[d_G^{(s)}] \subseteq S^\infty[d_{G'}^{(s+\epsilon)}]$ . This implies that  $\dim_{1\text{-acct-FS}}(X) \leq s + \epsilon = \dim_{\text{FS}}(X) + 2\epsilon$ .  $\square$

We have now shown that the finite-state dimension of a set is not affected by whether or not multiple accounts are allowed in the definition. However, if we use Theorem 4.5 to replace a  $k$ -account FSG by a 1-account FSG, then we are going from  $n$  states to roughly  $n \cdot k^{\frac{1}{\epsilon}}$  states. If we are trying to approximate the dimension to within  $r$  bits of accuracy, then  $\epsilon$  will be roughly  $2^{-r}$ , so our 1-account FSG will have roughly  $n \cdot k^{2^r}$  states.

At the time of this writing, we do not know whether such a large blowup in the number of states is necessary. If so, then the multi-account FSG model is quantitatively more powerful than the single-account FSG model, regardless of the qualitative identity in Corollary 4.6. If not, then we might be able to dispense with the multi-account feature. In any case, the following question appears to be significant.

**Question 4.7.** Given an  $n$ -state,  $k$ -account FSG  $G$ ,  $s \in [0, 1]$ , and  $\epsilon \in (0, 1)$ , how many states are required for a 1-account FSG  $G'$  satisfying  $S^\infty[d_G^{(s)}] \subseteq S^\infty[d_{G'}^{(s+\epsilon)}]$ ?

## 5 Rational Sequences

This section shows how to use finite-state dimension to define a natural notion of dimension in the set of all binary expansions of rational numbers.

**Definition.** Let  $n \in \mathbb{Z}^+$  and  $S \in \mathbf{C}$ .

1.  $S$  is *eventually periodic* with *period*  $n$ , and we write  $S \in \mathbf{Q}_n$ , if there exist  $x \in \{0,1\}^*$  and  $y \in \{0,1\}^n$  such that for all  $k \in \mathbb{N}$ ,  $xy^k \sqsubseteq S$ . In this case we write  $S = xy^\infty$ .
2.  $S$  is *eventually periodic*, and we write  $S \in \mathbf{Q}$ , if there exists  $n \in \mathbb{Z}^+$  such that  $S \in \mathbf{Q}_n$ .

Note that for all  $m, n \in \mathbb{Z}^+$ ,  $\mathbf{Q}_n \subseteq \mathbf{Q}_{mn}$ . Note also that  $\mathbf{Q} = \bigcup_{n=1}^{\infty} \mathbf{Q}_n$  is precisely the set of all binary expansions of elements of  $\mathbb{Q} \cap [0,1]$ . For this reason, the elements of  $\mathbf{Q}$  are also called *rational sequences*.

We now define dimension in the set of rational sequences.

**Definition.** For  $X \subseteq \mathbf{C}$ , the *dimension of  $X$  in  $\mathbf{Q}$*  is

$$\dim(X|\mathbf{Q}) = \dim_{\text{FS}}(X \cap \mathbf{Q}).$$

We shall see that this definition endows  $\mathbf{Q}$  with internal dimension structure. The following properties of dimension in  $\mathbf{Q}$  are clear from the definition and Theorem 3.10.

**Observation 5.1.** Let  $X, Y \subseteq \mathbf{C}$ .

1.  $0 \leq \dim(X|\mathbf{Q}) \leq \dim_{\text{FS}}(X) \leq 1$ .
2. If  $X \cap \mathbf{Q} \subseteq Y \cap \mathbf{Q}$ , then  $\dim(X|\mathbf{Q}) \leq \dim(Y|\mathbf{Q})$ .
3.  $\dim(X \cup Y|\mathbf{Q}) = \max \{ \dim(X|\mathbf{Q}), \dim(Y|\mathbf{Q}) \}$ .

We next show that, for fixed  $n$ , the set of all sequences with period at most  $n$  has dimension 0 in  $\mathbf{Q}$ .

**Lemma 5.2.** For all  $n \in \mathbb{Z}^+$ ,

$$\dim(\mathbf{Q}_n|\mathbf{Q}) = \dim_{\text{FS}}(\mathbf{Q}_n) = 0.$$

**Proof.** Let  $n \in \mathbb{Z}^+$ . For each  $r \in \mathbb{N}$  and  $y \in \{0,1\}^n$ , let  $X_{r,y}$  be the set of all  $S \in \mathbf{C}$  such that there exists  $x \in \{0,1\}^*$  such that  $|x| \equiv r \pmod n$  and for all  $k \in \mathbb{N}$ ,  $xy^k \sqsubseteq S$ . Then

$$\mathbf{Q}_n = \bigcup_{r=0}^{n-1} \bigcup_{y \in \{0,1\}^n} X_{r,y},$$

and this is a finite union, so it suffices by Theorem 3.10 to show that each  $\dim_{\text{FS}}(X_{r,y}) = 0$ . For this, fix  $0 \leq r < n$  and  $y \in \{0,1\}^n$ , and let  $s$  be such that  $0 < s < 1$  and  $2^{\frac{s}{2}} \in \mathbb{Q}$ . It suffices to show that  $\dim_{\text{FS}}(X_{r,y}) \leq s$ .

Define the 1-account,  $(r+n)$ -state gambler

$$G = (Q, \delta, \beta, -r),$$

where

$$Q = \{q \in \mathbb{Z} \mid -r \leq q < n\},$$

$$\delta(q, b) = \begin{cases} q + 1 & \text{if } q < n - 1 \\ 0 & \text{if } q = n - 1, \end{cases}$$

$$\beta(q) = \begin{cases} \frac{1}{2} & \text{if } q < 0 \\ 1 - 2^{-\frac{s}{2}} & \text{if } q \geq 0 \text{ and } y[q] = 0 \\ 2^{-\frac{s}{2}} & \text{if } q \geq 0 \text{ and } y[q] = 1. \end{cases}$$

For example, if  $n = 3$ ,  $r = 2$ , and  $y = 101$ , then  $G$  has the structure

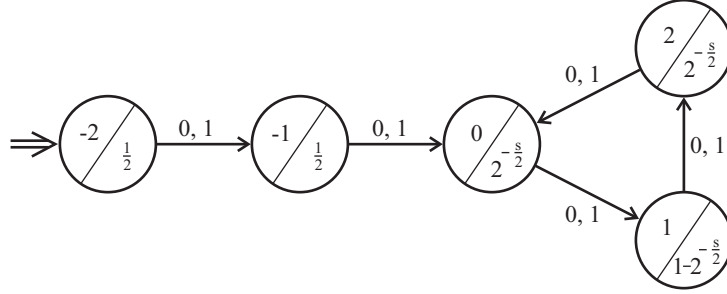

Suppose that  $S \in X_{r,y}$ . Then there exist  $x \in \{0,1\}^*$  and  $j \in \mathbb{N}$  such that  $|x| = jn + r$  and for all  $k \in \mathbb{N}$ ,  $xy^k \sqsubseteq S$ . Let  $u, v \in \{0,1\}^*$  be such that  $x = uv$  and  $|u| = r$ , and let  $\epsilon = \frac{s}{2}n$ ,  $a = (s-1)r + jn(s + \log(1 - 2^{-\frac{s}{2}}))$ . Since  $G$  does not bet on the first  $r$  bits of  $S$ , we have

$$d_G^{(s)}(u) = 2^{(s-1)r}.$$

Since  $2^{-\frac{s}{2}} > \frac{1}{2} > 1 - 2^{-\frac{s}{2}}$  and  $|v| = jn$ , we then have

$$\begin{aligned} d_G^{(s)}(x) &\geq d_G^{(s)}(u) \cdot 2^{s|v|} (1 - 2^{-\frac{s}{2}})^{|v|} \\ &= 2^{(s-1)r + sjn} (1 - 2^{-\frac{s}{2}})^{jn} \\ &= 2^a. \end{aligned}$$

It follows that for all  $k \in \mathbb{N}$ ,

$$\begin{aligned} d_G^{(s)}(xy^k) &= d_G^{(s)}(x) \cdot 2^{skn} (2^{-\frac{s}{2}})^{kn} \\ &\geq 2^{a+\epsilon k}. \end{aligned}$$

Since  $\epsilon > 0$ ,  $k$  is arbitrary, and  $xy^k \sqsubseteq S$ , it follows that  $d_G^{(s)}$  succeeds on  $S$ . This shows that  $X_{r,y} \subseteq S^\infty [d_G^{(s)}]$ , whence  $\dim_{\text{FS}}(X_{r,y}) \leq s$ .  $\square$

**Notation.** For  $n \in \mathbb{Z}^+$ , let  $\mathbf{Q}_{\leq n} = \bigcup_{k=1}^n \mathbf{Q}_k$ .

**Corollary 5.3.** For all  $n \in \mathbb{Z}^+$ ,

$$\dim(\mathbf{Q}_{\leq n} | \mathbf{Q}) = \dim_{\text{FS}}(\mathbf{Q}_{\leq n}) = 0.$$

**Proof.** This follows immediately from Lemma 5.2 and Theorem 3.10 □

**Corollary 5.4.** If  $X \subseteq \mathbf{C}$  and  $X \cap \mathbf{Q}$  is finite, then  $\dim(X | \mathbf{Q}) = 0$ .

In contrast with Lemma 5.2, and with the fact that every countable set of sequences has classical Hausdorff dimension 0, a set of sequences may have positive dimension in  $\mathbf{Q}$ . In fact, we show that the theorem of Eggleston [5] mentioned in the first paragraph of the present paper holds in  $\mathbf{Q}$ .

Define the *frequency* of a nonempty string  $w \in \{0, 1\}^*$  to be the ratio

$$\text{freq}(w) = \frac{\#(1, w)}{|w|},$$

where  $\#(b, w)$  denotes the number of occurrences of the bit  $b$  in  $w$ . For each  $S \in \mathbf{C}$  and  $n \in \mathbb{Z}^+$ , let

$$\text{freq}_S(n) = \text{freq}(S[0..n-1]).$$

For each  $\alpha \in [0, 1]$ , define the sets

$$\text{FREQ}(\alpha) = \left\{ S \in \mathbf{C} \mid \lim_{n \rightarrow \infty} \text{freq}_S(n) = \alpha \right\},$$

$$\text{FREQ}(\leq \alpha) = \left\{ S \in \mathbf{C} \mid \limsup_{n \rightarrow \infty} \text{freq}_S(n) \leq \alpha \right\}.$$

Note that if  $S = xy^\infty \in \mathbf{Q}$ , then  $S \in \text{FREQ}(\alpha)$ , where  $\alpha = \frac{\#(1, y)}{|y|} \in \mathbb{Q}$ .

The following theorem uses the binary entropy function

$$\mathcal{H} : [0, 1] \rightarrow [0, 1]$$

$$\mathcal{H}(x) = x \log \frac{1}{x} + (1-x) \log \frac{1}{1-x}$$

(The values of  $\mathcal{H}(0)$  and  $\mathcal{H}(1)$  are both 0, so that  $\mathcal{H}$  is continuous on  $[0, 1]$ .) The proof of the theorem uses the weighted binary entropy function

$$h : (0, 1)^2 \rightarrow [0, \infty)$$

$$h(x, y) = x \log \frac{1}{y} + (1-x) \log \frac{1}{1-y}.$$

This function is continuous on  $(0, 1)^2$ . For fixed  $x \in (0, 1)$ ,  $h(x, y)$  takes its minimum value  $\mathcal{H}(x)$  at  $y = x$  and strictly increases as  $y$  moves away from  $x$ .

**Theorem 5.5.** For all  $\alpha \in \mathbb{Q} \cap [0, 1]$ ,

$$\dim(\text{FREQ}(\alpha) | \mathbf{Q}) = \dim_{\text{FS}}(\text{FREQ}(\alpha)) = \mathcal{H}(\alpha).$$

**Proof.** By Observation 5.1 it suffices to show that

$$\dim_{\text{FS}}(\text{FREQ}(\alpha)) \leq \mathcal{H}(\alpha) \leq \dim(\text{FREQ}(\alpha) \mid \mathbf{Q}). \quad (5.1)$$

We prove that the first inequality holds for  $\alpha \in \mathbb{Q} \cap [0, \frac{1}{2}]$ . The proof that it holds for  $\alpha \in \mathbb{Q} \cap [\frac{1}{2}, 1]$  is analogous. Let  $\alpha \in \mathbb{Q} \cap [0, \frac{1}{2}]$ , and let  $s > \mathcal{H}(\alpha)$ . To prove the first inequality in (5.1), it suffices to show that

$$\dim_{\text{FS}}(\text{FREQ}(\alpha)) \leq s. \quad (5.2)$$

Let  $\epsilon = \frac{s - \mathcal{H}(\alpha)}{2}$ . If  $\alpha = 0$ , fix  $\delta \in \mathbb{Q} \cap (0, \frac{1}{2})$  such that  $\mathcal{H}(\delta) < \epsilon$ . If  $\alpha > 0$ , fix  $\delta \in \mathbb{Q} \cap (0, \frac{1}{2})$  such that  $[\alpha - \delta, \alpha + \delta]^2 \subseteq (0, 1)^2$  and for all  $(x, y) \in [\alpha - \delta, \alpha + \delta]^2$ ,  $h(x, y) < \mathcal{H}(\alpha) + \epsilon$ . Let

$$\beta = \begin{cases} \alpha & \text{if } \alpha > 0 \\ \delta & \text{if } \alpha = 0, \end{cases}$$

and let  $G$  be the 1-account, 1-state FSG

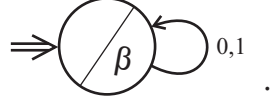

Note that for all  $w \in \{0, 1\}^*$ ,

$$d_G(w) = 2^{|w|} \beta^{\#(1, w)} (1 - \beta)^{\#(0, w)}. \quad (5.3)$$

To prove (5.2), it suffices to show that

$$\text{FREQ}(\alpha) \subseteq S^\infty[d_G^{(s)}]. \quad (5.4)$$

To see this, let  $S \in \text{FREQ}(\alpha)$ , and let  $w_n = S[0..n-1]$  for all  $n \in \mathbb{N}$ . Then there exists  $n_0 \in \mathbb{N}$  such that for all  $n \geq n_0$ ,  $\#(1, w_n) \leq (\alpha + \delta)n$ . Since  $1 - \beta \geq \beta$ , it follows by (5.3) and our choice of  $\delta$  that for all  $n \geq n_0$ ,

$$\begin{aligned} d_G(w_n) &\geq 2^n \beta^{(\alpha + \delta)n} (1 - \beta)^{n - (\alpha + \delta)n} \\ &= \left(2^{1 - h(\alpha + \delta, \beta)}\right)^n \\ &\geq \left(2^{1 - \mathcal{H}(\alpha) - \epsilon}\right)^n, \end{aligned}$$

whence

$$d_G^{(s)}(w_n) \geq 2^{(s-1)n} \left(2^{1 - \mathcal{H}(\alpha) - \epsilon}\right)^n = 2^{\epsilon n}.$$

Thus  $S \in S^\infty[d_G^{(s)}]$ , confirming (5.4) and thereby completing the proof of the first inequality in (5.1).

The second inequality in (5.1) is trivial for  $\alpha \in \{0, 1\}$ , so let  $\alpha \in \mathbb{Q} \cap (0, 1)$ , let  $s < \mathcal{H}(\alpha)$ , and let  $G = (Q, \delta, \beta, q_0)$  be a 1-account FSG. By Corollary 4.6, it suffices to show that

$$\text{FREQ}(\alpha) \cap \mathbf{Q} \not\subseteq S^\infty[d_G^{(s)}]. \quad (5.5)$$

Since  $\alpha$  is rational, we can write  $\alpha = \frac{k}{n}$ , where  $n \geq 2$  is chosen large enough that

$$n(\mathcal{H}(\alpha) - s) \geq 2 \log n. \quad (5.6)$$

(Note that  $0 < k < n$  because  $\alpha \in (0, 1)$ .) Let

$$B = \{u \in \{0, 1\}^n \mid \#(1, u) = k\}.$$

Using the well-known bound  $e \left(\frac{n}{e}\right)^n < n! < en \left(\frac{n}{e}\right)^n$ , it is easy to see that

$$\begin{aligned} |B| &= \binom{n}{k} > \frac{1}{ek(n-k)} 2^{n\mathcal{H}(\alpha)} \\ &\geq \frac{4}{en^2} 2^{n\mathcal{H}(\alpha)} > 2^{n\mathcal{H}(\alpha) - 2 \log n}, \end{aligned}$$

whence (5.6) tells us that

$$|B| > 2^{sn}. \quad (5.7)$$

Corollary 3.2 tells us that for each  $w \in \{0, 1\}^*$ , there are fewer than  $2^{sn}$  strings  $u \in \{0, 1\}^n$  for which  $d_G^{(s)}(wu) > d_G^{(s)}(w)$ . It follows by (5.7) that for each  $w \in \{0, 1\}^*$  there exists a string  $u(w) \in B$  such that  $d_G^{(s)}(wu(w)) \leq d_G^{(s)}(w)$ . For each  $i \in \mathbb{N}$ , define strings  $x_i \in \{0, 1\}^*$  and  $u_i \in B$  by the recursion

$$x_0 = \lambda, \quad u_i = u(x_i), \quad x_{i+1} = x_i u_i.$$

Since  $Q$  is finite, there exist  $i, j \in \mathbb{N}$  such that  $i < j$  and  $\delta(x_i) = \delta(x_j)$ . Let

$$x = x_i, \quad y = u_i \cdots u_{j-1}, \quad S = xy^\infty.$$

Since  $\text{freq}(u) = \alpha$  for all  $u \in B$ , we have  $\text{freq}(y) = \alpha$ , whence  $S \in \text{FREQ}(\alpha) \cap \mathbf{Q}$ . On the other hand, our choice of the strings  $u_i$  and our construction of  $S$  ensure that

$$d_G^{(s)}(S[0..in - 1]) \leq 1$$

for all  $i \in \mathbb{N}$ . It follows by Corollary 3.3 that for all  $m \in \mathbb{N}$ , if we write  $m = qn + r$ , where  $q, r \in \mathbb{N}$  and  $r < n$ , then

$$\begin{aligned} d_G^{(s)}(S[0..m - 1]) &\leq 2^{rs} d_G^{(s)}(S[0..qn - 1]) \\ &\leq 2^{rs} \\ &< 2^{ns}. \end{aligned}$$

Since  $n$  is constant here, this implies that  $S \notin S^\infty[d_G^{(s)}]$ , confirming (5.5) and concluding the proof of the second inequality in (5.1).  $\square$

**Corollary 5.6.** For all  $\alpha \in [0, \frac{1}{2}]$ ,

$$\dim(\text{FREQ}(\leq \alpha) \mid \mathbf{Q}) = \dim_{\text{FS}}(\text{FREQ}(\leq \alpha)) = \mathcal{H}(\alpha).$$

**Proof.** The proof of the first inequality in (5.1) actually shows that for all  $\alpha' \in \mathbb{Q} \cap [0, \frac{1}{2}]$ ,

$$\dim_{\text{FS}}(\text{FREQ}(\leq \alpha')) \leq \mathcal{H}(\alpha'). \quad (5.8)$$

Given an arbitrary  $\alpha \in [0, \frac{1}{2}]$  and  $\epsilon > 0$ , choose  $\alpha_1 \in \mathbb{Q} \cap [0, \alpha]$  and  $\alpha_2 \in \mathbb{Q} \cap [\alpha, \frac{1}{2}]$  such that  $\mathcal{H}(\alpha_1) \geq \mathcal{H}(\alpha) - \epsilon$  and  $\mathcal{H}(\alpha_2) \leq \mathcal{H}(\alpha) + \epsilon$ . Theorem 5.5 and monotonicity tell us that

$$\begin{aligned} \mathcal{H}(\alpha) - \epsilon &\leq \mathcal{H}(\alpha_1) \leq \dim(\text{FREQ}(\leq \alpha_1) \mid \mathbf{Q}) \\ &\leq \dim(\text{FREQ}(\leq \alpha) \mid \mathbf{Q}). \end{aligned}$$

Similarly, (5.8) and monotonicity tell us that

$$\begin{aligned} \dim_{\text{FS}}(\text{FREQ}(\leq \alpha)) &\leq \dim_{\text{FS}}(\text{FREQ}(\leq \alpha_2)) \\ &\leq \mathcal{H}(\alpha_2) \leq \mathcal{H}(\alpha) + \epsilon. \end{aligned}$$

Since  $\epsilon$  may be arbitrarily small here, it follows that

$$\dim_{\text{FS}}(\text{FREQ}(\leq \alpha)) \leq \mathcal{H}(\alpha) \leq \dim(\text{FREQ}(\leq \alpha) \mid \mathbf{Q}).$$

The corollary follows immediately from this. □

Finally, we note that the set of all rational sequences has finite-state dimension 1.

**Corollary 5.7.**  $\dim(\mathbf{Q} \mid \mathbf{Q}) = \dim_{\text{FS}}(\mathbf{Q}) = 1$ .

**Proof.** Taking  $\alpha = \frac{1}{2}$  in Theorem 5.5 and using monotonicity, we have  $\dim(\mathbf{Q} \mid \mathbf{Q}) \geq \dim(\text{FREQ}(\frac{1}{2}) \mid \mathbf{Q}) = \mathcal{H}(\frac{1}{2}) = 1$ . The corollary follows immediately. □

## 6 Individual Sequences

It is natural to define the finite-state dimension of an individual sequence as follows.

**Definition.** The *finite-state dimension* of a sequence  $S \in \mathbf{C}$  is

$$\dim_{\text{FS}}(S) = \dim_{\text{FS}}(\{S\}).$$

It is clear that  $\dim_{\text{FS}}(S) = \dim_{1\text{-acct-FS}}(\{S\})$ , i.e., it suffices to consider single-account FSGs when working with individual sequences.

We know the finite-state dimensions of normal sequences from the next result of Schnorr and Stimm [20] on 1-account FSGs. For each martingale  $d$ , let  $X(d)$  be the set of all  $S \in \mathbf{C}$  such that either

- (i)  $d$  is *eventually constant* on  $S$ , i.e.,  $d(S[0..n]) = d(S[0..n-1])$  for all sufficiently large  $n$ , or
- (ii)  $d$  *decays exponentially* on  $S$ , i.e., there exists  $\alpha \in (0, 1)$  such that  $d(S[0..n-1]) < \alpha^n$  for all sufficiently large  $n$ .

Recall from section 2 that  $\text{NORM}$  is the set of all normal sequences.

**Theorem 6.1.** (Schnorr and Stimm [20]). If  $G$  is a 1-account FSG, then  $\text{NORM} \subseteq X(d_G)$ .

By Theorem 6.1, every normal sequence has finite-state dimension 1. On the other hand, by Corollary 5.7, every rational sequence has finite-state dimension 0. The following theorem says that every rational number  $r \in [0, 1]$  is the finite-state dimension of a reasonably simple sequence.

**Theorem 6.2.** For every  $r \in \mathbb{Q} \cap [0, 1]$  there exists  $S \in \text{AC}_0$  such that  $\dim_{\text{FS}}(S) = r$ .

The rest of this section is a proof of Theorem 6.2. The case  $r = 1$  is given by Theorem 6.1 and the following known result.

**Theorem 6.3.** (Strauss [23]). There is a normal sequence in  $\text{AC}_0$ .

We use the following simple construction to obtain Theorem 6.2 from Theorem 6.3.

**Construction 6.4.** Given a rational number  $r \in [0, 1]$ , define the  $r$ -*dilution function*  $g_r : \mathbf{C} \rightarrow \mathbf{C}$  as follows. Write  $r = \frac{a}{b}$  in lowest terms, i.e.,  $a \in \mathbb{N}$ ,  $b \in \mathbb{Z}^+$ , and  $\gcd(a, b) = 1$ . Given  $S \in \mathbf{C}$  and  $i \in \mathbb{N}$ , let  $w_i$  be the  $i^{\text{th}}$  block of  $a$  bits of  $S$ , i.e.,  $w_i = S[ai .. a(i+1) - 1]$ . (Note that  $w_i = \lambda$  if  $r = 0$ .) Then

$$g_r(S) = w_0 0^{b-a} w_1 0^{b-a} \dots$$

**Lemma 6.5.** For all  $r \in \mathbb{Q} \cap [0, 1]$  and  $S \in \mathbf{C}$ ,

$$\dim_{\text{FS}}(g_r(S)) = r \cdot \dim_{\text{FS}}(S).$$

**Proof.**  $g_1(S) = S$  and  $g_0(S) = 0^\infty$  for all  $S \in \mathbf{C}$ , so these cases are obvious. Fix  $r \in \mathbb{Q} \cap (0, 1)$ ,  $S \in \mathbf{C}$ . Let  $a, b \in \mathbb{N}$  such that  $r = \frac{a}{b}$  in lowest terms.

To see that  $\dim_{\text{FS}}(g_r(S)) \leq r \cdot \dim_{\text{FS}}(S)$ , let  $s' > s > \dim_{\text{FS}}(S)$ . It suffices to show that  $\dim_{\text{FS}}(g_r(S)) \leq r \cdot s'$ . By our choice of  $s$ , there is a 1-account FSG  $G = (Q, \delta, \beta, q_0)$  such that  $S \in S^\infty[d_G^{(s)}]$ .

We define the 1-account FSG

$$G' = (Q', \delta', \beta', q'_0)$$

whose components are as follows.

(i)  $Q' = Q \times \{0, 1, \dots, b-1\}$ .

(ii) If  $i \leq a-1$ ,  $(q, i) \in Q'$ , and  $x \in \{0, 1\}$ ,

$$\delta'((q, i), x) = (\delta(q, x), (i+1)).$$

(iii) If  $a \leq i \leq b-1$ ,  $(q, i) \in Q'$ , and  $x \in \{0, 1\}$ ,

$$\delta'((q, i), x) = (q, (i+1) \bmod b).$$

(iv) If  $i \leq a-1$ ,  $(q, i) \in Q'$ ,

$$\beta'(q, i) = \beta(q).$$

(v) If  $a \leq i \leq b-1$ ,  $(q, i) \in Q'$ ,

$$\beta'(q, i) = 0.$$

(vi)  $q'_0 = (q_0, 0)$ .

If for each  $i$ ,  $w_i = S[ai \dots a(i+1) - 1]$ , then

$$d_{G'}(w_0 0^{b-a} w_1 0^{b-a} \dots w_{i-1} 0^{b-a}) = d_G(w_0 \dots w_{i-1}) 2^{(b-a)i}.$$

Since  $S \in S^\infty[d_G^{(s)}]$ ,  $d_G(w_0 \dots w_{i-1}) > 2^{(1-s)ia}$  and therefore

$$d_{G'}(w_0 0^{b-a} w_1 0^{b-a} \dots w_{i-1} 0^{b-a}) > 2^{(b-as)i}$$

and

$$d_{G'}^{(s'r)}(w_0 0^{b-a} w_1 0^{b-a} \dots w_{i-1} 0^{b-a}) > 2^{(s'r-1)bi} 2^{(b-as)i} = 2^{(s'-s)ai}.$$

Since  $s' > s$ ,  $g_r(S) \in S^\infty[d_{G'}^{(s'r)}]$  and  $\dim_{\text{FS}}(g_r(S)) \leq r \cdot s'$ .

To see that  $\dim_{\text{FS}}(g_r(S)) \geq r \cdot \dim_{\text{FS}}(S)$ , let  $s' < s < \dim_{\text{FS}}(S)$ . It suffices to show that  $\dim_{\text{FS}}(g_r(S)) \geq r \cdot s'$ . Let  $G = (Q, \delta, \beta, q_0)$  be a 1-account FSG. It suffices to show that  $g_r(S) \notin S^\infty[d_G^{(s'r)}]$ .

We define the 1-account FSG

$$G' = (Q', \delta', \beta', q'_0)$$

whose components are as follows.

(i)  $Q' = Q \times \{0, 1, \dots, a-1\}$ .

(ii) If  $i < a-1$ ,  $(q, i) \in Q'$ , and  $x \in \{0, 1\}$ ,

$$\delta'((q, i), x) = (\delta(q, x), i+1).$$

(iii) If  $(q, a-1) \in Q'$ , and  $x \in \{0, 1\}$ ,

$$\delta'((q, a-1), x) = (\delta(q, x 0^{b-a}), 0).$$

(iv) For all  $(q, i) \in Q'$ ,

$$\beta'(q, i) = \beta(q).$$

(vi)  $q'_0 = (q_0, 0)$ .

If for each  $i$ ,  $w_i = S[ai \dots a(i+1) - 1]$ , then

$$d_{G'}(w_0 \dots w_{i-1}) \geq d_G(w_0 0^{b-a} w_1 0^{b-a} \dots w_{i-1} 0^{b-a}) 2^{-(b-a)i}.$$

By our choice of  $s$ ,  $S \notin S^\infty[d_G^{(s)}]$ , and since  $s' < s$ ,  $d_{G'}(w_0 \dots w_{i-1}) < 2^{(1-s')ia}$ , therefore

$$d_G(w_0 0^{b-a} w_1 0^{b-a} \dots w_{i-1} 0^{b-a}) < 2^{(b-a)i} 2^{(1-s')ia} = 2^{(b-s'a)i} = 2^{(1-s'r)bi}.$$

So for each  $n \in \mathbb{N}$ ,  $d_G(g_r(S)[0 \dots n - 1]) < 2^{(1-s'r)n+b}$  and therefore  $g_r(S) \notin S^\infty[d_G^{(s'r)}]$  and  $\dim_{\text{FS}}(g_r(S)) \geq r \cdot s'$ .

□

**Lemma 6.6.** For all  $r \in \mathbb{Q} \cap [0, 1]$ ,  $g_r(\text{AC}_0) \subseteq \text{AC}_0$ .

**Proof.**  $g_1(S) = S$  and  $g_0(S) = 0^\infty$  for all  $S \in \mathbf{C}$ , so these cases are obvious. Fix  $r \in \mathbb{Q} \cap (0, 1)$ . Let  $a, b \in \mathbb{N}$  such that  $r = \frac{a}{b}$  in lowest terms. Let  $S \in \text{AC}_0$ . Let  $\{C_k \mid k \in \mathbb{N}\}$  be a family of  $\text{AC}_0$  circuits for  $S$ . We define a family of circuits that recognizes  $g_r(S)$ .

For each input  $x$  with  $|x| = m$ , a circuit will compute  $n$  such that  $x = s_n$ , then compute  $i = \lfloor n/b \rfloor$ , compute  $M = b \cdot i + a$ , compare  $n$  with  $M$ . If  $n \geq M$  then output 0. Otherwise use a circuit from  $C_{m-c}$  to  $C_m$  to decide  $y = s_{n-(b-a)i}$  (where  $c$  is a suitable constant for which  $|s_{n-(b-a)i}| \geq m - c$ ).

Since multiplication and division by a constant, as well as comparison and addition, can all be performed in  $\text{AC}_0$ ,  $g_r(S) \in \text{AC}_0$ .  $\square$

**Proof of Theorem 6.2.** Let  $r \in \mathbb{Q} \cap [0, 1]$ . By Theorem 6.3 there is a sequence  $S' \in \text{NORM} \cap \text{AC}_0$ . Then  $\dim_{\text{FS}}(S') = 1$  by Theorem 6.1. Let  $S = g_r(S')$ . Then  $\dim_{\text{FS}}(S) = r$  by Lemma 6.5, and  $S \in \text{AC}_0$  by Lemma 6.6.  $\square$

## 7 Dimension and Compression

In this section we characterize the finite-state dimensions of individual sequences in terms of finite-state compressibility. We first recall the definition of an information-lossless finite-state compressor. (This idea is due to Huffman [9]. Further exposition may be found in [11] or [12].)

**Definition.** A *finite-state compressor (FSC)* is a 4-tuple

$$C = (Q, \delta, \nu, q_0),$$

where

- $Q$  is a nonempty, finite set of *states*,
- $\delta : Q \times \{0, 1\} \rightarrow Q$  is the *transition function*,
- $\nu : Q \times \{0, 1\}^* \rightarrow \{0, 1\}^*$  is the *output function*, and
- $q_0 \in Q$  is the *initial state*.

For  $q \in Q$  and  $w \in \{0, 1\}^*$ , we define the *output* from state  $q$  on input  $w$  to be the string  $\nu(q, w)$  defined by the recursion

$$\begin{aligned} \nu(q, \lambda) &= \lambda, \\ \nu(q, wb) &= \nu(q, w)\nu(\delta(q, w), b) \end{aligned}$$

for all  $w \in \{0, 1\}^*$  and  $b \in \{0, 1\}$ . We then define the *output* of  $C$  on input  $w \in \{0, 1\}^*$  to be the string

$$C(w) = \nu(q_0, w).$$

**Definition.** An FSC  $C = (Q, \delta, \nu, q_0)$  is *information-lossless (IL)* if the function

$$\begin{aligned} \{0, 1\}^* &\rightarrow \{0, 1\}^* \times Q \\ w &\mapsto (C(w), \delta(w)) \end{aligned}$$

is one-to-one. An *information-lossless finite-state compressor (ILFSC)* is an FSC that is IL.

That is, an ILFSC is an FSC whose input can be reconstructed from the output and final state reached on that input.

**Example 7.1.** (Scheinwald [19]). The diagram

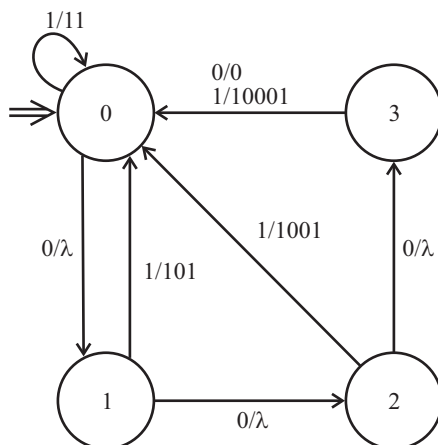

denotes the FSC  $C = (Q, \delta, \nu, 0)$ , where  $Q = \{0, 1, 2, 3\}$  and for all  $q \in Q$  we have  $\delta(q, 0) = (q + 1) \bmod 4$ ,  $\delta(q, 1) = 0$ ,  $\nu(q, 0) = \lambda$  if  $q \leq 2$ ,  $\nu(3, 0) = 0$ , and  $\nu(q, 1) = 10^q 1$ . It can be seen that  $C$  is IL. For example, if  $C(w) = 00101$  and  $\delta(w) = 3$ , it must be the case that  $w = 000000001000$ .

Intuitively, an FSC  $C$  compresses a string  $w$  if  $|C(w)|$  is significantly less than  $|w|$ . Of course, if  $C$  is IL, then not all strings can be compressed. Our interest here is in the degree (if any) to which the prefixes of a given sequence  $S \in \mathbf{C}$  can be compressed by an ILFSC.

**Definition.** If  $C$  is an FSC and  $S \in \mathbf{C}$ , then the *compression ratio* of  $C$  on  $S$  is

$$\rho_C(S) = \liminf_{n \rightarrow \infty} \frac{|C(S[0..n-1])|}{n}.$$

**Definition.** The *finite-state compression ratio* of a sequence  $S \in \mathbf{C}$  is

$$\rho_{\text{FS}}(S) = \inf \{ \rho_C(S) \mid C \text{ is an ILFSC} \}.$$

The following theorem says that finite-state dimension and finite-state compressibility are one and the same for individual sequences.

**Theorem 7.2.** For all  $S \in \mathbf{C}$ ,

$$\dim_{\text{FS}}(S) = \rho_{\text{FS}}(S).$$

The rest of this section is devoted to proving Theorem 7.2. We first examine a particular method of constructing finite-state gamblers from a finite-state compressor.

**Construction 7.3.** Given an FSC  $C = (Q, \delta, \nu, q_0)$  and  $k \in \mathbb{Z}^+$ , we define the 1-account FSG

$$G = G(C, k) = (Q', \delta', \beta', q'_0)$$

whose components are as follows.

(i)  $Q' = Q \times \{0, 1, \dots, k-1\}$ .

(ii) For all  $(q, i) \in Q'$  and  $b \in \{0, 1\}$ ,

$$\delta'((q, i), b) = (\delta(q, b), (i+1) \bmod k).$$

(iii) For all  $(q, i) \in Q'$ ,

$$\beta'(q, i) = \frac{\sigma(q, 1 \{0, 1\}^{k-i-1})}{\sigma(q, \{0, 1\}^{k-i})},$$

where  $\sigma(q, A) = \sum_{u \in A} 2^{-|\nu(q, u)|}$ .

(iv)  $q'_0 = (q_0, 0)$ .

**Lemma 7.4.** In Construction 7.3, if  $|w|$  is a multiple of  $k$  and  $u \in \{0, 1\}^{\leq k}$ , then

$$d_G(wu) = 2^{|\nu(\delta(w), u)|} \frac{\sigma(\delta(wu), \{0, 1\}^{k-|u|})}{\sigma(\delta(w), \{0, 1\}^k)} d_G(w).$$

**Proof.** We use induction on the string  $u$ . If  $u = \lambda$  the lemma is clear. Assume that it holds for  $u$ , where  $u \in \{0, 1\}^{< k}$ , and let  $b \in \{0, 1\}$ . Then

$$\begin{aligned} d_G(wub) &= 2 \frac{\sigma(\delta(wu), b \{0, 1\}^{k-|u|-1})}{\sigma(\delta(wu), \{0, 1\}^{k-|u|})} d_G(wu) \\ &= 2^{1-|\nu(\delta(wu), b)|} \frac{\sigma(\delta(wub), \{0, 1\}^{k-|u|-1})}{\sigma(\delta(wu), \{0, 1\}^{k-|u|})} d_G(wu), \end{aligned}$$

so by the induction hypothesis the lemma holds for  $wub$ . □

**Lemma 7.5.** In Construction 7.3, if  $w = w_0 w_1 \cdots w_{n-1}$ , where each  $w_i \in \{0, 1\}^k$ , then

$$d_G(w) = \frac{2^{|w|-|C(w)|}}{\prod_{i=0}^{n-1} \sigma(\delta(w_0 \cdots w_{i-1}), \{0, 1\}^k)}.$$

**Proof.** We use induction on  $n$ . For  $n = 0$ , the identity is clear. Assume that it holds for  $n$ . Let  $w' = w_0 w_1 \cdots w_n$  where each  $w_i \in \{0, 1\}^k$ , and let  $w = w_0 w_1 \cdots w_{n-1}$ . Then Lemma 7.4 with  $u = w_n$  tells us that

$$d_G(w') = \frac{2^{|w_n| - |\nu(\delta(w), w_n)|}}{\sigma(\delta(w), \{0, 1\}^k)} d_G(w),$$

whence the identity holds for  $w'$  by the induction hypothesis.  $\square$

**Lemma 7.6.** In Construction 7.3, if  $C$  is IL and  $|w|$  is a multiple of  $k$ , then

$$d_G(w) \geq 2^{|w| - |C(w)| - \frac{|w|}{k} (2 \lceil \log |Q| \rceil + 1)}.$$

**Proof.** Assume the hypothesis. Let  $l = \lceil \log |Q| \rceil$ , and for each  $q \in Q$ , let  $\#q \in \{0, 1\}^l$  be an  $l$ -bit encoding of  $q$ . Since  $C$  is IL, for each  $z \in \{0, 1\}^*$ , the function  $g_z : \{0, 1\}^* \rightarrow \{0, 1\}^*$  defined by

$$g_z(w) = 0^l \# \delta(zw) \nu(\delta(z), w)$$

for all  $w \in \{0, 1\}^*$  is one-to-one. Also, the range of  $g_z$  is an instantaneous code, so the Kraft inequality tells us that for all  $z \in \{0, 1\}^*$ ,

$$\sum_{w \in \{0, 1\}^*} 2^{-(2l+1) - |\nu(\delta(z), w)|} = \sum_{w \in \{0, 1\}^*} 2^{-|g_z(w)|} \leq 1,$$

whence

$$\sum_{w \in \{0, 1\}^*} 2^{-|\nu(\delta(z), w)|} \leq 2^{2l+1}.$$

This implies that for all  $z \in \{0, 1\}^*$ ,

$$\sigma(\delta(z), \{0, 1\}^k) \leq 2^{2l+1}.$$

It follows by Lemma 7.5 that

$$d_G(w) \geq 2^{|w| - |C(w)| - \frac{|w|}{k} (2l+1)}.$$

$\square$

**Lemma 7.7.** In Construction 7.3, if  $C$  is IL, then for all  $w \in \{0, 1\}^*$ ,

$$d_G(w) \geq 2^{|w| - |C(w)| - \frac{|w|}{k} (2l+1) - (km+2l+1)},$$

where  $l = \lceil \log |Q| \rceil$  and  $m = \max \{|\nu(q, 0)| \mid q \in Q\}$ .

**Proof.** Assume the hypothesis, let  $l$  and  $m$  be as given, and let  $w \in \{0, 1\}^*$ . Fix  $0 \leq j < k$  such that  $|w| + j$  is divisible by  $k$ . By Lemma 7.6, we have

$$\begin{aligned} d_G(w) &\geq 2^{-j} d_G(w0^j) \\ &\geq 2^{-j + |w0^j| - |C(w0^j)| - \frac{|w0^j|}{k} (2l+1)} \\ &= 2^{|w| - |C(w0^j)| - \frac{|w|}{k} (2l+1) - \frac{j}{k} (2l+1)} \\ &\geq 2^{|w| - |C(w)| - \frac{|w|}{k} (2l+1) - (km+2l+1)}. \end{aligned}$$

□

We next examine a method of constructing information-lossless finite-state compressors from a non-vanishing 1-account finite-state gambler.

**Construction 7.8.** Let  $G = (Q, \delta, \beta, q_0)$  be a nonvanishing 1-account FSG, and let  $k \in \mathbb{Z}^+$ . For each  $q \in Q$ , let  $G_q = (Q, \delta, \beta, q)$ , and define  $p_q : \{0, 1\}^k \rightarrow [0, 1]$  by  $p_q(w) = 2^{-k} d_{G_q}(w)$ . Since  $G$  is nonvanishing and each  $d_{G_q}$  is a martingale with  $d_{G_q}(\lambda) = 1$ , each of the functions  $p_q$  is a positive probability measure on  $\{0, 1\}^k$ . For each  $q \in Q$ , let  $\Theta_q : \{0, 1\}^k \rightarrow \{0, 1\}^*$  be the Shannon-Fano-Elias code (see, for example [4]) given by the probability measure  $p_q$ . Then

$$|\Theta_q(w)| = l_q(w),$$

where

$$l_q(w) = 1 + \left\lceil \log \frac{1}{p_q(w)} \right\rceil$$

for all  $q \in Q$  and  $w \in \{0, 1\}^k$ , and each of the sets  $\text{range}(\Theta_q)$  is an instantaneous code. We define the FSC

$$C = C(G, k) = (Q', \delta', \nu', q'_0)$$

whose components are as follows.

- (i)  $Q' = Q \times \{0, 1\}^{<k}$ .
- (ii) For all  $(q, w) \in Q'$  and  $b \in \{0, 1\}$ ,

$$\delta'((q, w), b) = \begin{cases} (q, wb) & \text{if } |w| < k - 1 \\ (\delta(q, wb), \lambda) & \text{if } |w| = k - 1. \end{cases}$$

- (iii) For all  $(q, w) \in Q'$  and  $b \in \{0, 1\}$ ,

$$\nu'((q, w), b) = \begin{cases} \lambda & \text{if } |w| < k - 1 \\ \Theta_q(wb) & \text{if } |w| = k - 1. \end{cases}$$

- (iv)  $q'_0 = (q_0, \lambda)$ .

Since each  $\text{range}(\Theta_q)$  is an instantaneous code, it is easy to see that the FSC  $C = C(G, k)$  is IL.

**Lemma 7.9.** In Construction 7.8, if  $|w|$  is a multiple of  $k$ , then

$$|C(w)| \leq \left(1 + \frac{2}{k}\right) |w| - \log d_G(w).$$

**Proof.** Let  $w = w_0 w_1 \cdots w_{n-1}$ , where each  $w_i \in \{0, 1\}^k$ . For each  $0 \leq i < n$ , let  $q_i = \delta(w_0 \cdots w_{i-1})$ .

Then

$$\begin{aligned}
|C(w)| &= \sum_{i=0}^{n-1} l_{q_i}(w_i) \\
&= \sum_{i=0}^{n-1} \left( 1 + \left\lceil \log \frac{1}{\rho_{q_i}(w_i)} \right\rceil \right) \\
&\leq \sum_{i=0}^{n-1} \left( 2 + \log \frac{2^k}{d_{G_{q_i}}(w_i)} \right) \\
&= (k+2)n - \log \prod_{i=0}^{n-1} d_{G_{q_i}}(w_i) \\
&= (k+2)n - \log d_G(w) \\
&= \left( 1 + \frac{2}{k} \right) |w| - \log d_G(w).
\end{aligned}$$

□

**Lemma 7.10.** In Construction 7.8, for all  $w \in \{0, 1\}^*$ ,

$$|C(w)| \leq \left( 1 + \frac{2}{k} \right) |w| - \log d_G(w).$$

**Proof.** Let  $w = w'z$ , where  $|w'|$  is a multiple of  $k$  and  $|z| = j < k$ . Then Lemma 7.9 tells us that

$$\begin{aligned}
|C(w)| &= |C(w')| \\
&\leq \left( 1 + \frac{2}{k} \right) |w'| - \log d_G(w') \\
&\leq \left( 1 + \frac{2}{k} \right) |w'| - \log(2^{-j} d_G(w)) \\
&= \left( 1 + \frac{2}{k} \right) |w| - \log d_G(w) - \frac{2j}{k} \\
&\leq \left( 1 + \frac{2}{k} \right) |w| - \log d_G(w).
\end{aligned}$$

□

We now use Constructions 7.3 and 7.8 to prove the main result of this section.

**Proof of Theorem 7.2.** Let  $S \in C$ . For each  $n \in \mathbb{N}$ , let  $w_n = S[0..n-1]$ .

To see that  $\dim_{\text{FS}}(S) \leq \rho_{\text{FS}}(S)$ , let  $s > s' > \rho_{\text{FS}}(S)$ . It suffices to show that  $\dim_{\text{FS}}(S) \leq s$ . By our choice of  $s'$ , there is an ILFSC  $C = (Q, \delta, \nu, q_0)$  for which the set

$$I = \left\{ n \in \mathbb{N} \mid |C(w_n)| < s'n \right\}$$

is infinite. Let  $l = \lceil \log |Q| \rceil$ , and fix  $k \in \mathbb{Z}^+$  such that  $\frac{2l+1}{k} < s - s'$ . Let  $G = G(C, k)$  be as in

Construction 7.3. Then by Lemma 7.7, for all  $n \in I$  we have

$$\begin{aligned} d_G^{(s)}(w_n) &\geq 2^{sn - |C(w)| - \frac{2}{k}(2l+1) - (km+2l+1)} \\ &\geq 2^{(s-s' - \frac{2l+1}{k})n - (km+2l+1)}. \end{aligned}$$

Since  $s - s' - \frac{2l+1}{k} > 0$ , this implies that  $S \in S^\infty[d_G^{(s)}]$ . Thus  $\dim_{\text{FS}}(S) \leq s$ .

To see that  $\rho_{\text{FS}}(S) \leq \dim_{\text{FS}}(S)$  let  $s > s' > s'' > \dim_{\text{FS}}(S)$ . It suffices to show that  $\rho_{\text{FS}}(S) \leq s$ . By our choice of  $s''$ , there is a 1-account FSG  $G$  such that the set

$$J = \left\{ n \in \mathbb{N} \mid d_G^{(s'')}(w_n) \geq 1 \right\}$$

is infinite. By Lemma 3.11, there is a nonvanishing 1-account FSG  $G'$  such that  $d_{G'}(w) \geq 2^{(s''-s')|w|} d_G(w)$  for all  $w \in \{0,1\}^*$ . Fix  $k > \frac{2}{s-s'}$ , and let  $C = C(G', k)$  be as in Construction 7.8. Then Lemma 7.10 tells us that for all  $n \in J$ ,

$$\begin{aligned} |C(w_n)| &\leq \left(1 + \frac{2}{k}\right) n - \log d_{G'}(w_n) \\ &\leq \left(1 + \frac{2}{k} + s' - s''\right) n - \log d_G(w_n) \\ &\leq \left(\frac{2}{k} + s'\right) n - \log d_G^{(s'')}(w_n) \\ &\leq \left(\frac{2}{k} + s'\right) n \\ &< sn. \end{aligned}$$

Thus  $\rho_{\text{FS}}(S) \leq s$ . □

It is worthwhile to examine the number of states used in the proof of Theorem 7.2. Consider first the proof that  $\dim_{\text{FS}}(S) \leq \rho_{\text{FS}}(S)$ . If the compressor  $C$  has  $n$  states and we want the gambler  $G$  to approximate  $\rho_{\text{FS}}(S)$  to within  $r$  bits of accuracy, then  $s - s'$  is  $\Theta(2^{-r})$ , so  $k$  is  $\Theta(2^r \log n)$ , so  $G$  has  $\Theta(2^r n \log n)$  states. This increase in the number of states is modest because, roughly speaking, only  $O(r + \log n)$  more hardware is required to implement  $G$  than to implement  $C$ .

Conversely, consider the proof that  $\rho_{\text{FS}}(S) \leq \dim_{\text{FS}}(S)$ . If the gambler  $G$  has  $n$  states and we want the compressor  $C$  to approximate  $\dim_{\text{FS}}(S)$  to within  $r$  bits of accuracy, then  $s - s'$  is  $\Theta(2^{-r})$ , so  $k$  is  $\Theta(2^r)$ , so  $C$  has  $\Theta(n \cdot 2^k) = \Theta(n \cdot 2^{2^r})$  states. This is a very large increase in the number of states. At the time of this writing, we do not know whether such a large increase is necessary or merely an artifact of the present proof. That is, the following question is open.

**Question 7.11.** Given an  $n$ -state, 1-account FSG  $G$ ,  $s \in [0, 1]$ , and  $\epsilon \in (0, 1)$ , how many states are required for an ILFSC  $C$  such that  $\rho_C(S) \leq s + \epsilon$  for all  $S \in S^\infty[d_G^{(s)}]$ ?

Theorem 7.2 tells us that finite-state dimension of a sequence  $S$  can be defined using either FSGs or ILFSCs. Question 7.11 asks whether FSGs are significantly more succinct than ILFSCs for this purpose.

## 8 Conclusion

We have used finite-state gamblers to effectivize the gale characterization of classical Hausdorff dimension, thereby defining finite-state dimension in the Cantor space  $\mathbf{C}$  and in the space  $\mathbf{Q}$  of all rational binary sequences. We have shown that Eggleston's classical theorem on limiting frequencies holds for finite-state dimension in both  $\mathbf{Q}$  and  $\mathbf{C}$ . We have shown that the finite-state dimensions of individual sequences can be equivalently defined using either 1-account finite-state gamblers or information-lossless finite-state compressors, but our proof suggests that far more states may be required in the latter model. Similarly, we have shown that the finite-state dimensions of sets of sequences can be equivalently defined using either multi-account finite-state gamblers or 1-account finite-state gamblers, but our proof suggests that far more states may be needed in the latter model. It is to be hoped that the quantitative relationships among these three finite-state models will be clarified in the near future.

In any case, finite-state dimension is a real-time effectivization of a powerful tool of fractal geometry. As such it should prove to be a useful tool for improving our understanding of real-time information processing.

## Acknowledgment

We thank Giora Slutzki for useful discussions.

## References

- [1] P. Billingsley. *Ergodic Theory and Information*. John Wiley & Sons, 1965.
- [2] É. Borel. Sur les probabilités dénombrables et leurs applications arithmétiques. *Rend. Circ. Mat. Palermo*, 27:247–271, 1909.
- [3] J. Cai and J. Hartmanis. On Hausdorff and topological dimensions of the Kolmogorov complexity of the real line. *Journal of Computer and Systems Sciences*, 49:605–619, 1994.
- [4] T. M. Cover and J. A. Thomas. *Elements of Information Theory*. John Wiley & Sons, Inc., New York, N.Y., 1991.
- [5] H.G. Eggleston. The fractional dimension of a set defined by decimal properties. *Quarterly Journal of Mathematics*, Oxford Series 20:31–36, 1949.
- [6] K. Falconer. *The Geometry of Fractal Sets*. Cambridge University Press, 1985.
- [7] M. Feder. Gambling using a finite state machine. *IEEE Transactions on Information Theory*, 37:1459–1461, 1991.
- [8] F. Hausdorff. Dimension und äusseres Mass. *Math. Ann.*, 79:157–179, 1919.
- [9] D. A. Huffman. Canonical forms for information-lossless finite-state logical machines. *IRE Trans. Circuit Theory CT-6 (Special Supplement)*, pages 41–59, 1959. Also available in E.F. Moore (ed.), *Sequential Machine: Selected Papers*, Addison-Wesley, 1964, pages 866–871.

- [10] D.S. Johnson. A catalog of complexity classes. In J. van Leeuwen, editor, *Handbook of Theoretical Computer Science, Volume A*, pages 67–181. Elsevier, 1990.
- [11] Z. Kohavi. *Switching and Finite Automata Theory (Second Edition)*. McGraw-Hill, 1978.
- [12] A. A. Kurmit. *Information-Lossless Automata of Finite Order*. Wiley, 1974.
- [13] J. I. Lathrop and M. J. Strauss. A universal upper bound on the performance of the Lempel-Ziv algorithm on maliciously-constructed data. In B. Carpentieri, editor, *Compression and Complexity of Sequences '97*, pages 123–135. IEEE Computer Society Press, 1998.
- [14] J. H. Lutz. Dimension in complexity classes. In *Proceedings of the Fifteenth Annual IEEE Conference on Computational Complexity*, pages 158–169. IEEE Computer Society Press, 2000.
- [15] J. H. Lutz. Gales and the constructive dimension of individual sequences. In *Proceedings of the 27th Colloquium on Automata, Languages and Programming*, pages 902–913. Springer Lecture Notes in Computer Science, 2000.
- [16] B. Ya. Ryabko. Noiseless coding of combinatorial sources. *Problems of Information Transmission*, 22:170–179, 1986.
- [17] B. Ya. Ryabko. Algorithmic approach to the prediction problem. *Problems of Information Transmission*, 29:186–193, 1993.
- [18] B. Ya. Ryabko. The complexity and effectiveness of prediction problems. *Journal of Complexity*, 10:281–295, 1994.
- [19] D. Scheinwald. On the Lempel-Ziv proof and related topics. *Proceedings of the IEEE*, 82:866–871, 1994.
- [20] C. P. Schnorr and H. Stimm. Endliche automaten und zufallsfolgen. *Acta Informatica*, 1:345–359, 1972.
- [21] L. Staiger. Kolmogorov complexity and Hausdorff dimension. *Information and Computation*, 102:159–194, 1993.
- [22] L. Staiger. A tight upper bound on Kolmogorov complexity and uniformly optimal prediction. *Theory of Computing Systems*, 31:215–229, 1998.
- [23] M. J. Strauss. Normal numbers and sources for BPP. *Theoretical Computer Science*, 178:155–169, 1997.
- [24] J. Ziv. Coding theorem for individual sequences. *IEEE Transactions on Information Theory*, 24:405–412, 1978.
- [25] J. Ziv and A. Lempel. Compression of individual sequences by variable rate coding. *IEEE Transactions on Information Theory*, 24:530–536, 1978.